

GYROPILOT 2 computer

product reference : 90-60-130



INSTALLATION GUIDE

REV 2

nke – Sail racing

Z.I. Kerandré – Rue Gutenberg – 56700 HENNEBONT- FRANCE
<http://www.nke.fr> – After-sales service 0 33 297 365 685.

SOMMAIRE

1	PRESENTATION	3
2	INSTALLING THE HYDRAULIC UNIT	4
2.1	PREPARING THE RUDDER ARM.....	4
2.2	INSTALLATION OF THE HYDRAULIC LINEAR DRIVE	5
2.3	INSTALLATION OF THE HYDRAULIC PUMP	7
2.4	INSTALLATION OF THE RUDDER ANGLE SENSOR	7
3	INSTALLATION AND CONNECTING THE COMPUTER	9
3.1	PACKING LIST	9
3.2	LIST OF ACCESSORIES	9
3.3	INSTALLING AND LOCATION OF THE COMPUTER <i>GYROPILOT 2</i>	9
3.4	ELECTRIC DIAGRAM OF <i>GYROPILOT 2 RVP</i> COMPUTER (REVERSIBLE PUMP)	10
3.5	ELECTRIC DIAGRAM <i>GYROPILOT 2 CRP</i> COMPUTER.....	12
3.6	CONNECTING THE POWER SUPPLY OF THE LINEAR DRIVE MOTOR.....	14
3.7	CONNECTING THE COMPUTER TO TOPLINE BUS.....	15
3.8	TECHNICAL SPECIFICATION.....	16
3.9	SOFTWARE COMPUTER VERSION.....	16
3.10	DIAGNOSTIC FOR 1 ST LEVEL TROUBLES SHOOTING.	16
4	INITIALISATION OF THE COMPUTER.....	17
4.1	INITIALISATION.....	17
4.2	FIRST START-UP OF THE PILOT	18

1 PRESENTATION

This installation guide gives you all information :

- To install the **computer Gyropilot 2**
- To install **rudder angle sensor**
- To install de the hydraulic unit
- To get the optimal performances from your pilot and your boat.

See the installation guide for **fluxgate compass** and **multifonction Gyrographic**.

Installation architecture

The presence of the equipment in the following diagram is for information only, and does not represent the equipment of your installation.

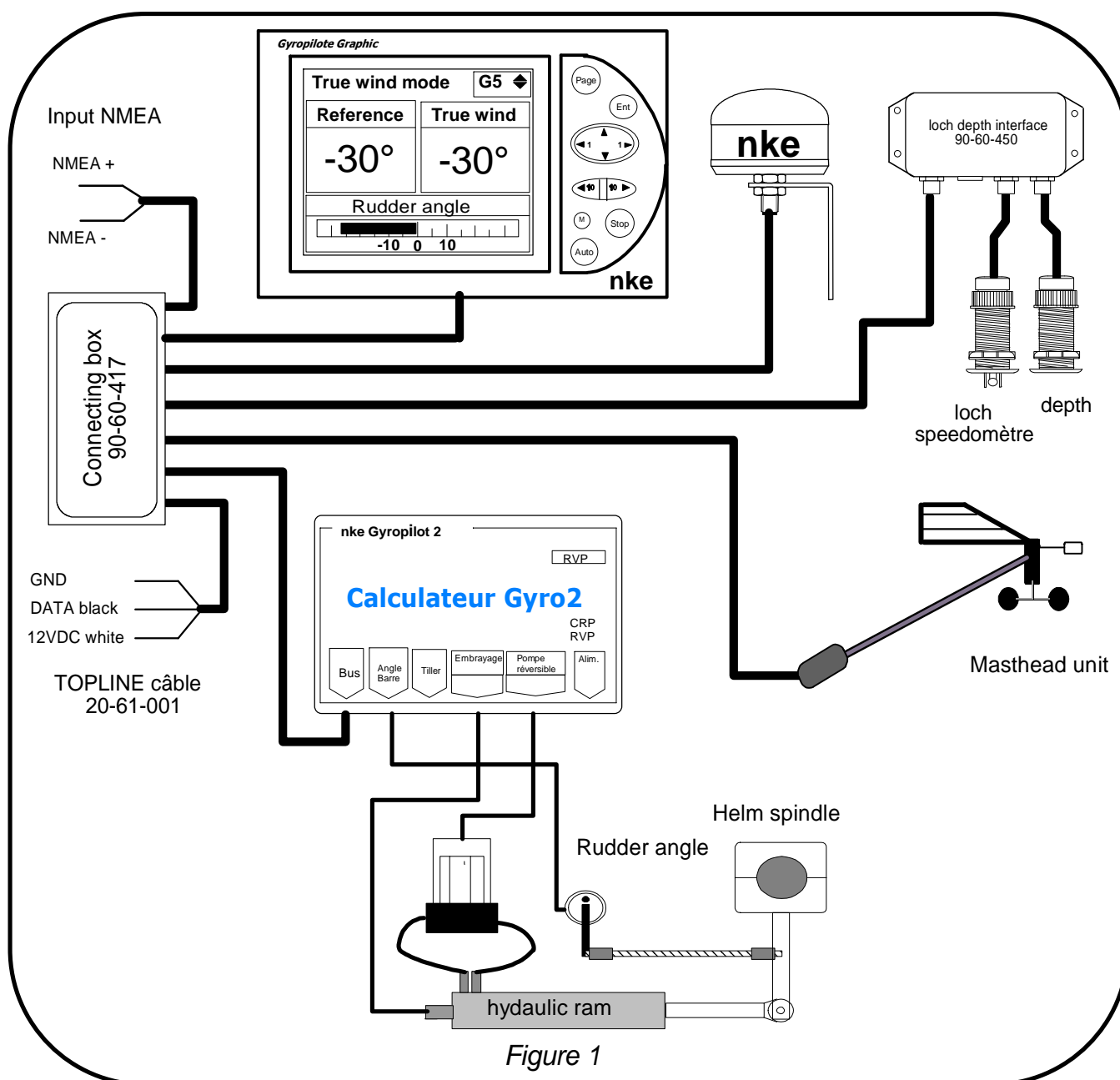

Figure 1

2 INSTALLING THE HYDRAULIC UNIT

Read this guide entirely before starting the installation .

Read the installation manual the hydraulic linear drive manufacture.

2.1 Preparing the rudder arm

If it is not possible to install the drive unit directly to the steering quadrant, then you will have to buy and install a rudder arm for your rudder shaft. The rudder arm can be mounted on the rudder shaft in any direction.

Make sure that the ruder arm can freely move 35° in both directions and that there is enough room available to mount the drive unit and rudder angle sensor as per the following sections.

Check with your boat manufacturer for special instructions on mounting autopilots to your rudder shaft or your quadrant

Drill a Ø 16mm hole to mount the hydraulic linear drive axis:

- 240mm from ruder axis for **pack type 60**

Drill a Ø 14mm hole to mount the hydraulic linear drive axis:

- 190mm from ruder axis **pack type 40**
- 170mm from ruder axis **pack type 32**
- 150mm from ruder axis **pack type 27**

Drill a Ø 12mm hole to mount the hydraulic linear drive axis:

- 129mm from ruder axis **pack type mini**

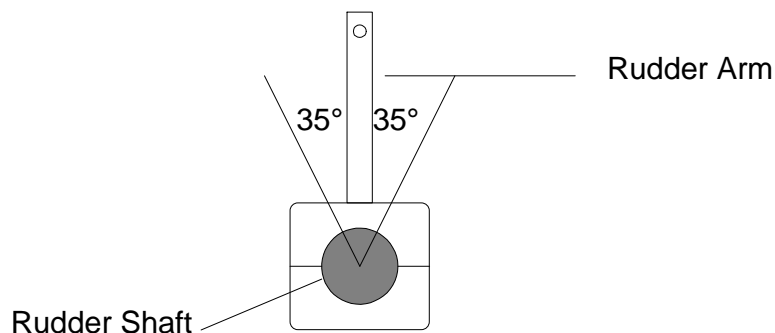

2.2 Installation of the hydraulic linear drive

WARNING:

The force developed by a hydraulic linear drive is very strong and could result in serious damage if impropally installed.

The linear drive and the hydraulic pump must be positioned on an horizontal plan.

Make sure that the linear drive support is positioned in the way that the rudder arm or rudder sector is in the same horizontal plan as the linear drive axis.

The mounting of the linear must be very rigid and you should not hesitate to strengthen it with a stainless steel plate strongly attached to the boat.

The rod of the cylinder is very fragile, and must not receive shocks, which could cause the rip of the lip seal and therefore an oil leak.

2.2.1 Linear drive for inboard mounting

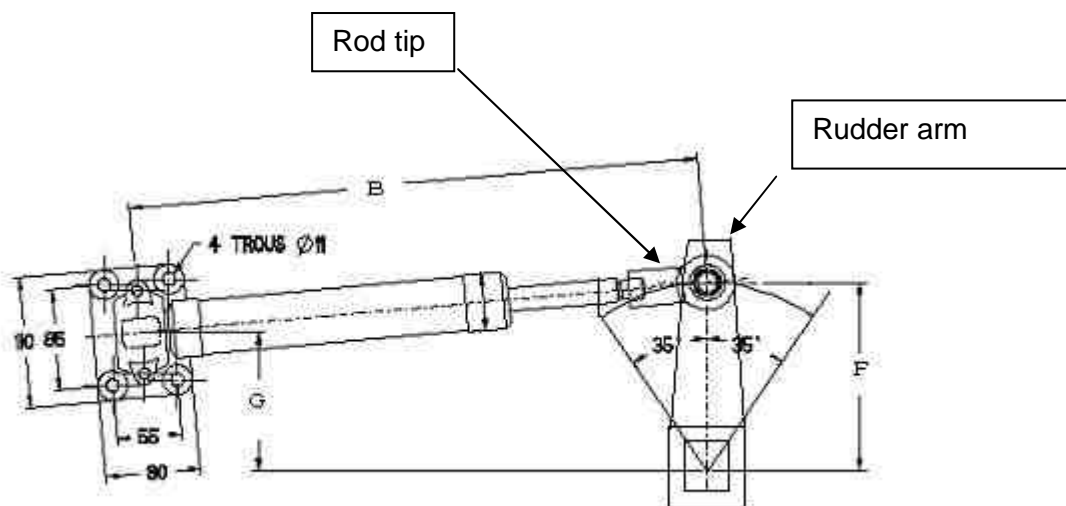

You will find with the hydraulic linear drive, the manufacturer mounting instructions.

Dimensions for installation

Pack type	B the rod half the way out	F	G
60	727mm	240mm	218mm
40	627mm	190mm	172,5mm
32	533mm	170mm	160mm
27	472mm	150mm	136,5mm
Mini	395mm	129mm	117mm

2.2.2 Hydraulic linear drive type 40 for outboard mounting

You will find with the hydraulic linear drive, the manufacturer mounting instructions.

Dimensions for installation hydraulic linear drive type 40 outboard

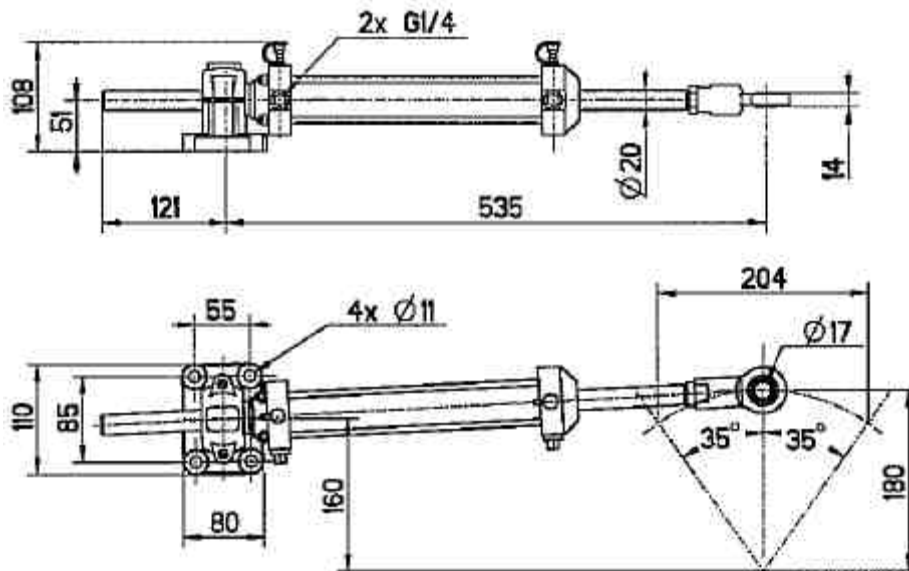

2.2.3 Installation procedure

- Put the rudder to the axis
- Unscrew half the way the tip at the end of the drive rod, and pull the rod half the way out such as the length between the axis of the linear support and the thrust axis is equal to the rod length
- Place the linear drive at 90° of the rudder arm
- Fixed it with 4 stainless steel screws and nuts.
- Grease the thrust axis of the linear drive and fix it on the rudder arm or rudder sector with the supplied nylstop nut.
- Adjust the rod tip on the same axis than the thrust axis and block it in position with the counter-nut.
- Insert the thrust axis in the rod tip and block it with a lynch pin.

WARNING:

Check that the mechanical rudder stops are in use. If the linear drive is used as a rudder stop, it could be irretrievably damaged.

2.3 Installation of the hydraulic pump

Select a location where it is easy to access to the pump for maintaining : oil adjust, speed setting.

Fix the pump with 4 screw and nuts \varnothing 6mm, on **an horizontal plan**.

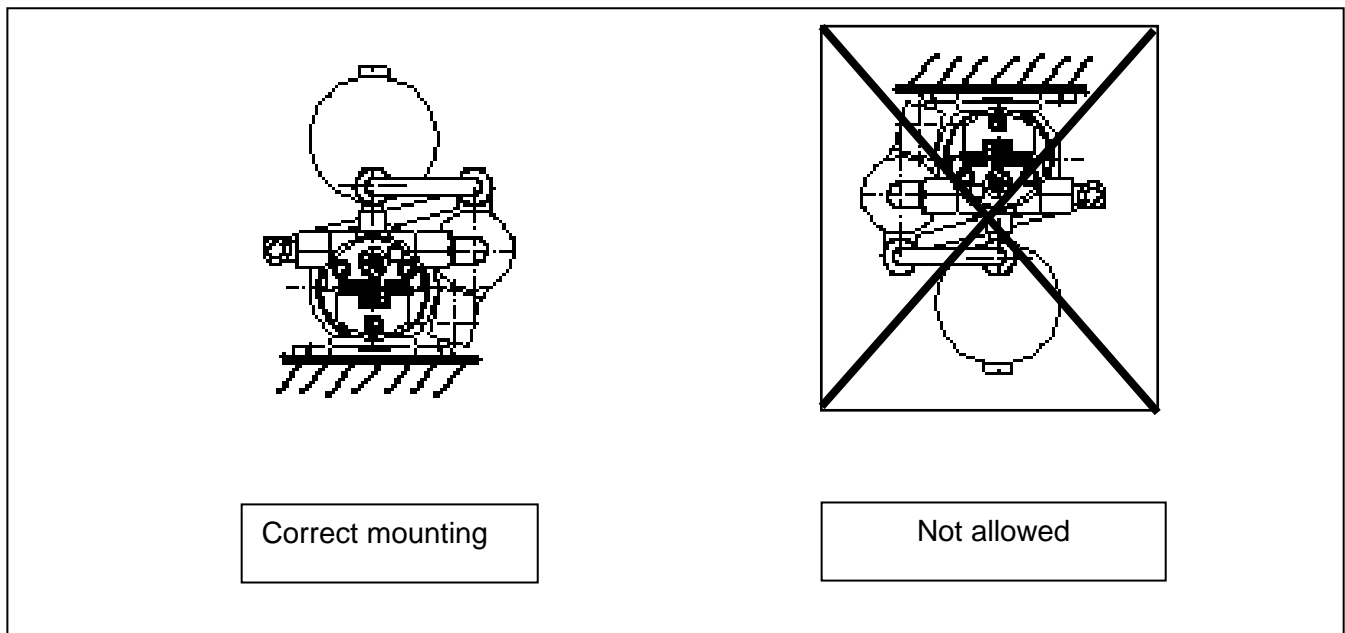

WARNING:

Don't forget before start up , remove the shipping cap on the top of the oil tank and replace it by the evented cap supplied with the hydraulic unit.

2.4 Installation of the rudder angle sensor

2.4.1 Precautions

- The sensor arm must be able to move $\pm 90^\circ$ UNOBSTRU CTED.
- When the rudder is centred, the sensor arm must also be centred (in relation to the axis screw head-see below).
- Distance "A" must be equal to "B".
- The sensor connector must be 90° to the rudder arm when the rudder is centred.
- It must be installed in a safe/dry location and away from interfering equipment (radio receivers, compressors, speakers, generators, etc.)
- The mounting location must be rigid and with **the sensor arm and the rudder arm in the same horizontal plan**.

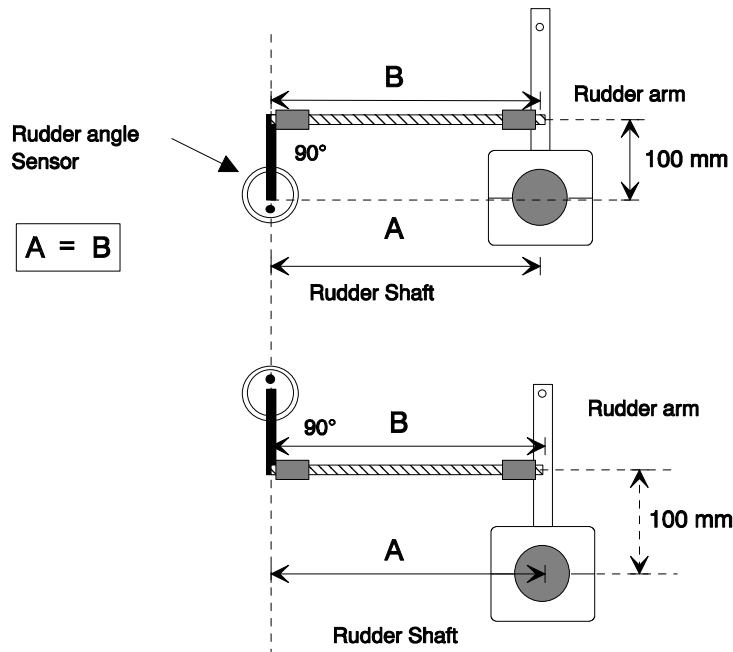

2.4.2 Installation procedure

1. Present the threaded rod in front of the rudder shaft, measure the maximum distance where you can place the sensor, in function of the rod length. The sensor arm will have to be able to rotate by 70° in both ways.
2. Measure precisely the distance A
3. Carefully centre the sensor so that the straight line going by the axis of the sensor arm and the blocking nut is parallel to the rudder arm.
4. Drill a \varnothing 7mm hole and mount the threaded connector arm to the rudder arm and the sensor arm.
5. Then, cut the threaded rod such as value $L = A - 22\text{mm}$
6. Mount the tips on the threaded rod, and block them with the counter nuts.
7. Before mounting the rod and tips on the connector arm, test manually your installation : maintain the tips just above each connector, and move the rudder from Port to starboard. If the parallelism is good, you can mount the tips on the connector arms.

WARNING :

When the rudder is centred, the rudder arm of the angle sensor must also be centred and parallel to the rudder arm.

The threaded rod must always be parallel to the linear drive axis. If not, this could seriously damage the sensor.

The A length of the threaded rod must be less than 360mm.

3 INSTALLATION AND CONNECTING THE COMPUTER

3.1 Packing list

- One **computer Gyropilote 2**, with its connecting cables.
- One installation guide.
- One **TOPLINE** bus cable.

3.2 List of accessories

- Standard terminal box TOPLINE bus : 90-60-121
- Terminal box TOPLINE bus with NMEA input : 90-60-417

3.3 Installing and location of the computer *Gyropilot 2*

Precautions

The gyrometer sensor, essential to have good performances with the pilot, is integrated in the computer Gyropilot 2. As this sensor is very sensible, the computer must be :

- **Mounted on a vertical wall,**
- It is screw with 4 screw \varnothing 4mm and the cable outlet are to the bottom.
- The location must be dry, above 50°C and not subjected to excessive vibrations

ATTENTION :

- During fixing, tighten the nuts moderately. An excessive tightening can cause a break of the case.
- Do not use silicon glue to mount the computer.

3.4 Electric diagram of Gyropilot 2 RVP computer (reversible pump)

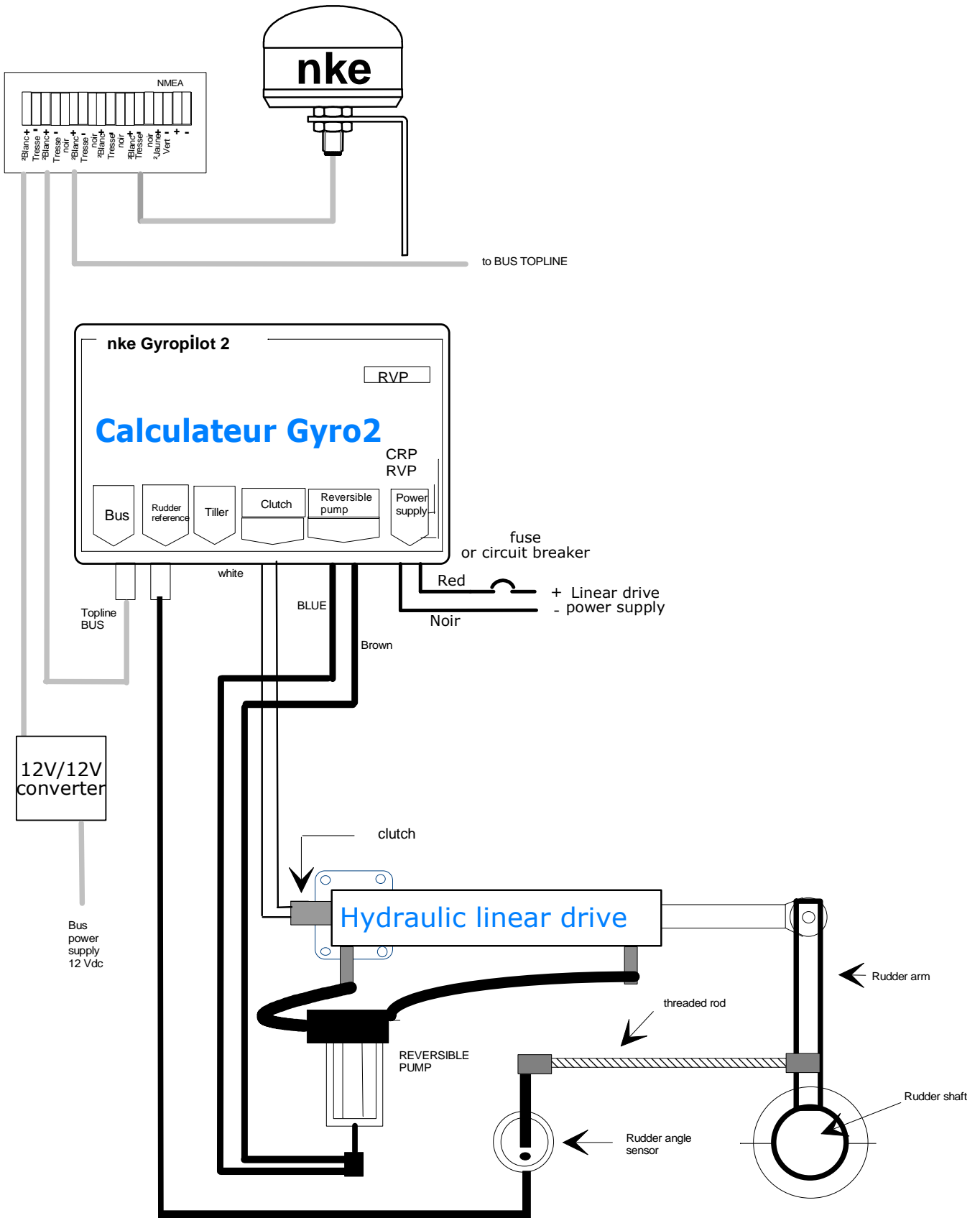

GYROPILOT 2 RVP computer : bottom side

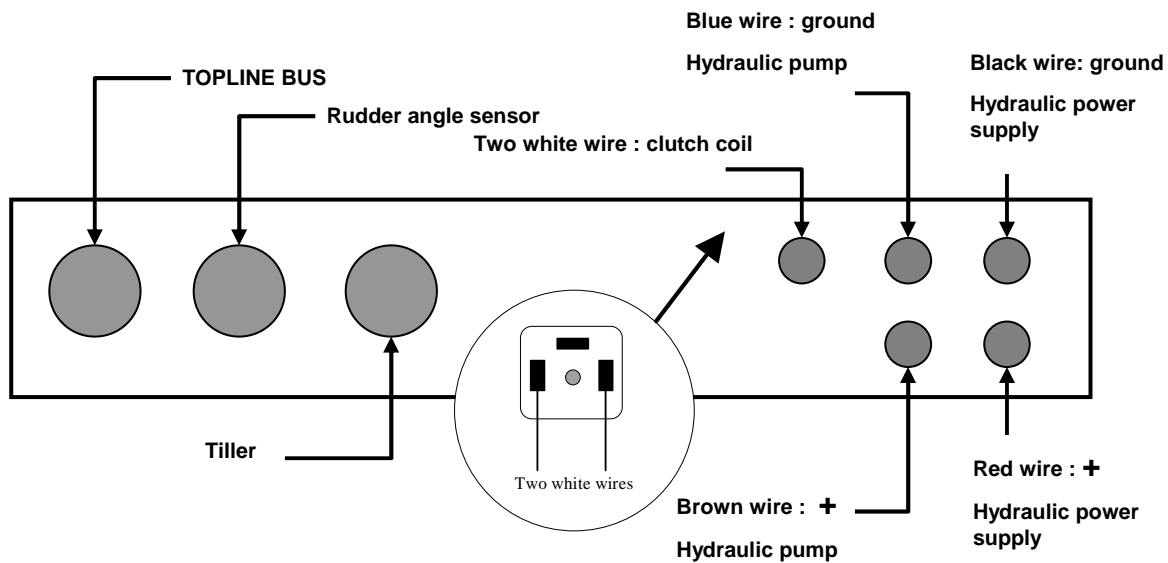

3.5 Electric diagram *Gyropilot 2 CRP* computer

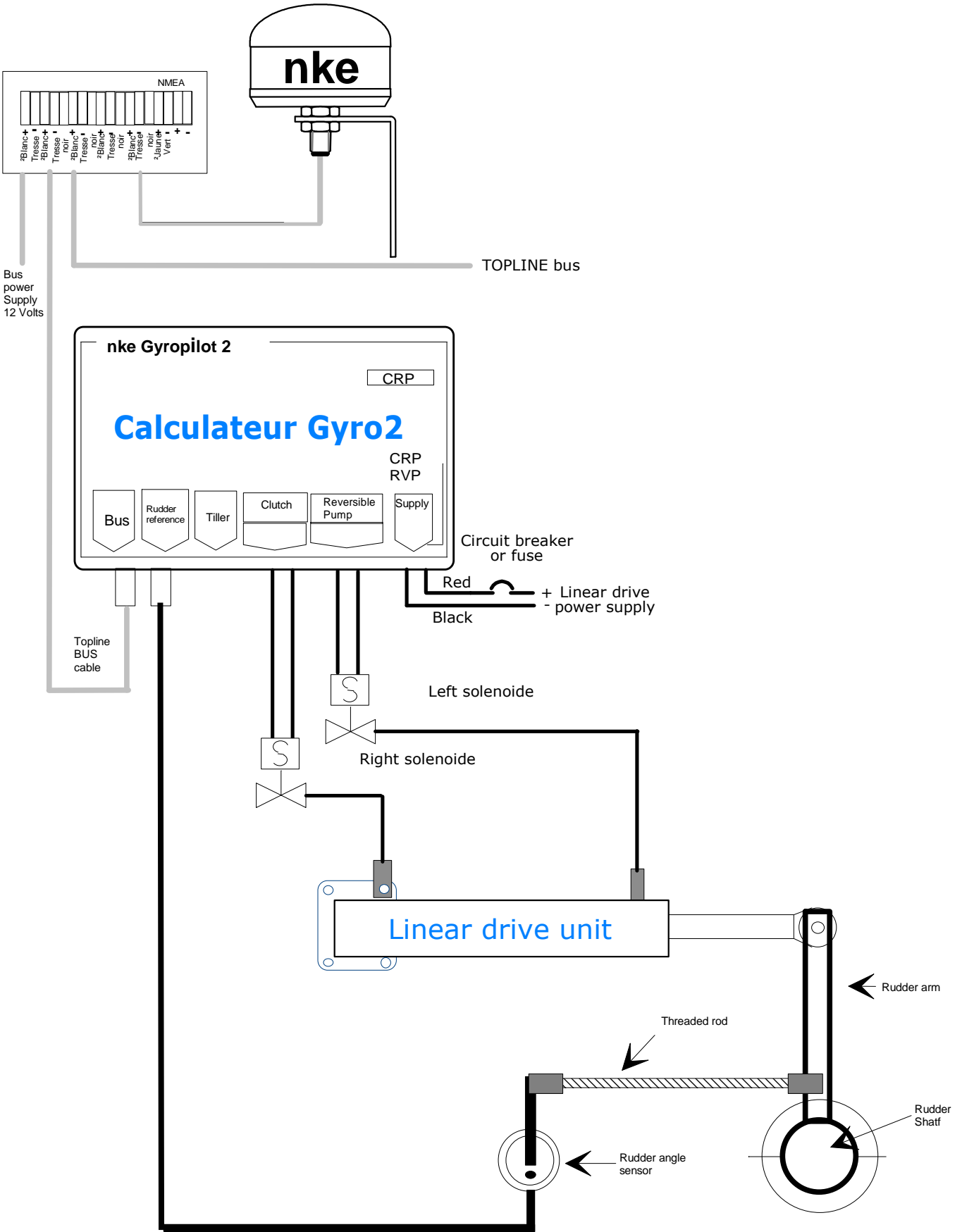

3.5.1 GYROPILOT 2 CRP computer : bottom side

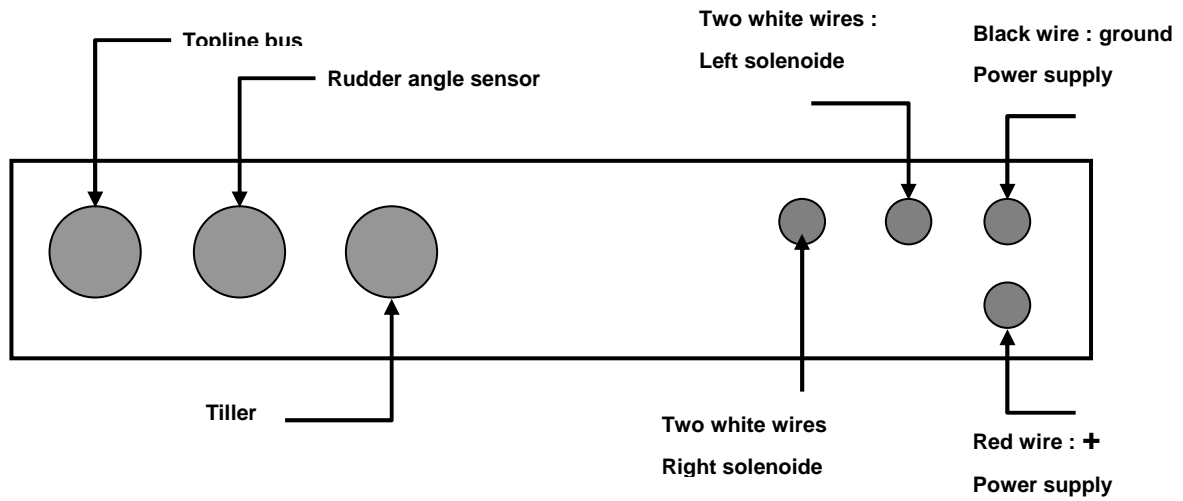

The GYROPILOT 2 **CRP** computer is designed to drive the solenoids of an hydraulic system ; This hydraulic system is generally mounted on big boat.

3.6 Connecting the power supply of the linear drive motor

ATTENTION:

The **Gyropilot 2** computer is designed to supply the linear power supply with 12VDC or 24VDC, but the **TOPLINE** bus must always be supplied with 12VDC.

The supply power wires, from the computer and linear drive to the power battery, must be as short as possible.

It is necessary to protect the linear drive power supply, using a fuse or a circuit breaker on the red wire : 30A for a 12VDC supply and 16A for a 24VDC supply.

Recommended wire section to supply the power battery to the linear drive motor.

Length from battery to the linear drive motor, via the Gyropilot 2 computer	Recommended section
3 m	2,5 mm ²
5 m	4 mm ²
7 m	6 mm ²
10 m	10 mm ²

A too low section cause heating of cable and decrease the performances of the Gyropilot.

As the electric power of the solenoid are low, it is not necessary to connect the power supply with higher electric wires diameter.

WARNING:

To avoid drop voltage on the **TOPLINE BUS**, it is strongly recommended to use two Batteries : one for the linear drive unit power and another one for the **TOPLINE BUS** and the instrument. If it is not possible on your boat, use a DC/DC 12V converter to separate the **TOPLINE BUS** From the linear drive unit power.

WARNING:

After a longtime (some months) without drive unit activity

Suggestion : To connect the clutch directly on your battery, because at the first time after this long time the clutch will request a big current to start and the internal fuse of the autopilot computer will down ! To repair that, we must send back your computer in factory.

3.7 Connecting the computer to Topline bus

1. Make the **computer** bus cable run towards the **TOPLINE** terminal box of your installation.
2. Connect the bus cable inside the terminal box :

If you reduce the length of the bus cable, strip and galvanise the wires before connecting them inside the terminal box.

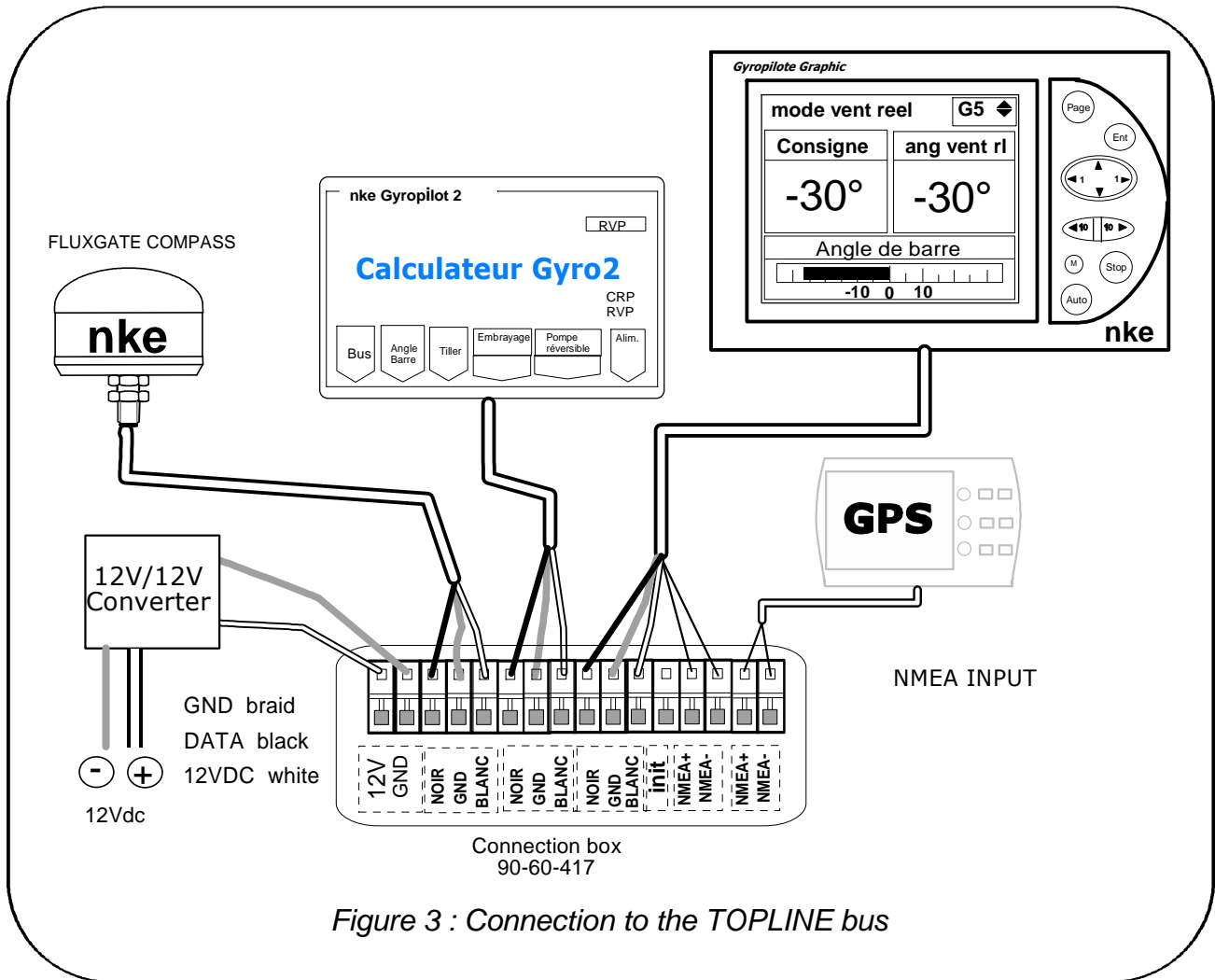

Figure 3 : Connection to the TOPLINE bus

3.8 Technical specification

- Supply : 10 à 16VDC
- Consumption : 50mA, without the hydraulic linear unit.
- IP protection : IP67
- Weight : 1kg, with cable
- Dimensions : width = 210mm ; height = 134mm ; thickness = 42mm
- Operating temperature : -10°C à +50°C
- Temperature of storage : -20°C à +60°C

3.9 Software computer version

The software version is indicated on the label of the product.

3.10 Diagnostic for 1st level troubles shooting.

This chapter can help you rapidly resolve minor problems which do not require the intervention of a specialist. Before contacting technical support, please check the troubleshooting table below.

Problem	Possible causes and solutions
The Topline installation does not detect the Gyropilot Graphic	The bus cable is not or is badly connected to the terminal box : check the plugging and the connection inside the terminal box. Check the state of the cables : they must not show any sign of wear or cut.
The Gyropilot Graphic displays the message « master absent »	Initialise the Gyropilot Graphic : see installation chapter.
The Gyropilot Graphic displays the message « bus error . The data cable (black) is in short-circuit »	Check that the black data wire is properly connected inside the terminal box : see installation chapter.
The Gyropilot Graphic display three dashes « - - - » in place of the data of a channel.	Check the sensor of this channel, check the connection cable : it may be damaged or disconnected.
The Gyropilot Graphic displays the message « bus error : conflict problem »	It may be that there are two master displays (at address 1) on your installation : check the addresses, if that is the case, reinitialise one of the displays.
The Gyropilot Graphic does not display the NMEA data : those from the GPS for example.	Has the NMEA link been initialised ? see NMEA initialisation chapter The NMEA link is not or is badly connected to the terminal box : check the connection of the Gyropilot Graphic and that of the NMEA transmitter (GPS). see installation chapter.
The Gyropilot Graphic displays the message « low battery »	Check the voltage of your battery with a voltmeter : the operating voltage must be above 10VDC. Check that the battery maintains the load.
The Gyropilot Graphic indicates « Error EPROM ».	Reinitialise your Gyropilot Graphic . If the error message persists, please contact your distributor.

If you do not manage to solve the problem, please contact your distributor.

4 INITIALISATION OF THE COMPUTER

This chapter describes the initialisation of the **Gyropilot 2 computer** and the **Gyropilot Graphic**. See also the **Gyropilot Graphic** user manual.

4.1 Initialisation

After installing the **Gyropilot**, you must initialise the whole of your pilot system. This is required in order to perform the training of the **Gyropilot computer**: position the rudder at the centre, then into limit stop on starboard side and finally into limit stop on port side, so that the computer stores these positions of the rudder. These three rudder positions are essential for the good operation of the cylinder of the pilot.

Follow the menu « **Pilot Initialisation** » of the **Gyropilot Graphic** which will guide you along the procedure.

Procedure

- Using the **Page** key, select the **Main menu** page,
- then using the browser, select **Configuration** then **Pilot initialisation**,
- press the **Ent** key,
- the following message is displayed « *This procedure will erase current settings. Press the **Ent** key to start. Press the **Page** key to exit* », press the **Ent** key,

the **Gyropilot Graphic** will guide you through the positioning of the rudder : follow the indications :

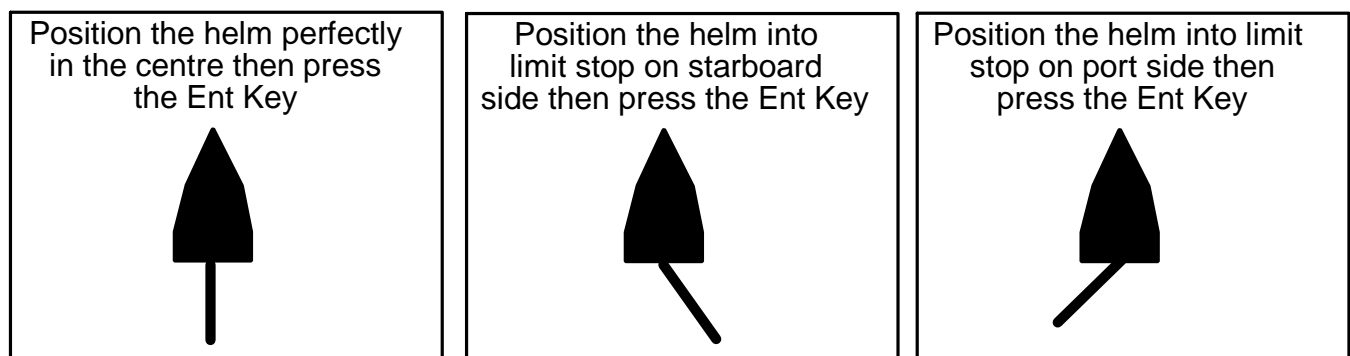

- After performing an auto test, your pilot is initialised,
- Exit this menu by pressing the **Page** key.

WARNING :

Inadequate initialisation of the pilot can lead to premature wear of the parts, poor heading maintenance by the pilot and excessive electrical consumption.

If you are unsure about your setting, perform the initialisation once again.

4.2 First start-up of the pilot

See the **Gyropilot Graphic** user manual.

Note that powering up or powering down your installation is done using the auxiliary switch of the electric switchboard of your boat. Your installation must comprise two separate 12V power supplies : one for power to the hydraulic pump and to the computer and the other for the **Gyropilot Graphic**, the **TOPLINE** bus and the sensors. If it is not possible to have 2 batteries pack you must set up a converter 12V/12V.

WARNING : It is imperative that you power the autopilot breaker before the Topline breaker. This allows the instruments system to recognise the Gyropilot

